



Designation: D1195/D1195M – 21

Standard Test Method for Repetitive Static Plate Tests of Soils and Flexible Pavement Components for Use in Evaluation and Design of Airport and Highway Pavements¹

This standard is issued under the fixed designation D1195/D1195M; the number immediately following the designation indicates the year of original adoption or, in the case of revision, the year of last revision. A number in parentheses indicates the year of last reappraisal. A superscript epsilon (ϵ) indicates an editorial change since the last revision or reappraisal.

1. Scope

1.1 This test method covers the apparatus and procedure for making repetitive static plate load tests on subgrade soils and compacted pavement components, in either the compacted condition or the natural state, and is to provide data for use in the evaluation and design of rigid and flexible-type airport and highway pavements.

1.2 The values stated in either SI units or inch-pound units are to be regarded separately as standard. The values stated in each system may not be exact equivalents; therefore, each system shall be used independently of the other. Combining values from the two systems may result in nonconformance with the standard.

1.3 *This standard does not purport to address all of the safety concerns, if any, associated with its use. It is the responsibility of the user of this standard to establish appropriate safety, health, and environmental practices and determine the applicability of regulatory limitations prior to use.*

1.4 *This international standard was developed in accordance with internationally recognized principles on standardization established in the Decision on Principles for the Development of International Standards, Guides and Recommendations issued by the World Trade Organization Technical Barriers to Trade (TBT) Committee.*

2. Referenced Documents

2.1 *ASTM Standards:*²

[A572/A572M Specification for High-Strength Low-Alloy Columbium-Vanadium Structural Steel](#)

¹ This test method is under the jurisdiction of ASTM Committee E17 on Vehicle - Pavement Systems and is the direct responsibility of Subcommittee E17.41 on Pavement Testing and Evaluation.

Current edition approved Aug. 1, 2021. Published August 2021. Originally approved in 1952. Last previous edition approved in 2015 as D1195/D1195M – 09 (2015). DOI: 10.1520/D1195_D1195M-21.

² For referenced ASTM standards, visit the ASTM website, www.astm.org, or contact ASTM Customer Service at service@astm.org. For *Annual Book of ASTM Standards* volume information, refer to the standard's Document Summary page on the ASTM website.

2.2 *AASHTO Standard:*³

[T 221 Standard Method of Test for Repetitive Static Plate Load Tests of Soils and Flexible Pavement Components for Use in Evaluation and Design of Airport and Highway Pavements](#)

2.3 *German Standard:*⁴

[DIN 18134 Soil—Testing Procedures and Testing Equipment—Plate Load Test](#)

3. Terminology

3.1 *Definitions:*

3.1.1 *deflection, n*—the amount of downward vertical movement of a surface due to the application of a load to the surface.

3.1.2 *modulus of subgrade reaction (k_s), n*—the ratio of the normal stress σ_0 under an area load to the associated settlements “s.”

3.1.3 *plate load test, n*—a test in which a load is repeatedly applied and released in increments using a circular loading plate aided by a loading device, with the settlement of the loading plate being measured.

3.1.4 *rebound deflection, n*—the amount of vertical rebound of a surface that occurs when a load is removed from the surface.

3.1.5 *residual deflection, n*—the difference between original and final elevations of a surface resulting from the application and removal of one or more loads to and from the surface.

3.1.6 *strain modulus (E_v), n*—a parameter expressing the deformation characteristics of a soil, calculated from the secants of the load settlement curves obtained from the first or repeat loading cycle between points $0.3 - \sigma_{0max}$ and $0.7 - \sigma_{0max}$.

4. Summary of Test Method

4.1 This test method is used to evaluate the strength of subgrade soils and unbound pavement components, in either

³ Available from American Association of State Highway and Transportation Officials (AASHTO), 444 N. Capitol St., NW, Suite 249, Washington, DC 20001, <http://www.transportation.org>.

⁴ Available from Deutsches Institut für Normung e.V.(DIN), Am DIN-Platz, Burggrafenstrasse 6, 10787 Berlin, Germany, <http://www.din.de>.

the compacted condition or the natural state, for use in the design of rigid and flexible-type airport and highway pavements.

4.2 The test method requires the use of a loading device/hydraulic jack assembly pushing rigid bearing plates into the test material with instrumentation recording settlement of the plates and the force of the jack against the loading device.

4.3 The test procedure requires the incremental loading and unloading of the rigid plates to prescribed stresses and then holding for a period of time to allow the settlement to stabilize. The results are plotted on a load settlement curve to determine bearing capacity or modulus of subgrade reaction.

5. Significance and Use

5.1 Field, in-place repetitive static plate load tests are used for the evaluation and design of pavement structures. Repetitive static plate load tests are performed on soils and unbound base and subbase materials to determine strain modulus or a measure of the shear strength of pavement components.

6. Apparatus

6.1 Presented below are analog and digital configurations with manual and electronic data collection methods. It is intended that either apparatus configuration is suitable for performing all of the test methods presented in Section 11.

6.2 The following apparatus describes the analog or dial gauge system that requires the data to be collected manually.

6.2.1 *Loading Device*—A truck or trailer or a combination of both a tractor-trailer, an anchored frame, or other structure loaded with sufficient weight to produce the desired reaction on the surface under test. The supporting points (wheels in the case of a truck or trailer) shall be at least 2.4 m [8 ft] from the circumference of the largest diameter bearing plate being used.

6.2.2 *Hydraulic Jack Assembly*, with a spherical bearing attachment, capable of applying and releasing the load in

increments. The jack shall have sufficient capacity for applying the maximum load required, and shall be equipped with an accurately calibrated gauge that will indicate the magnitude of the applied load.

6.2.3 *Bearing Plates*—A set of circular steel bearing plates not less than 25.4 mm [1 in.] in thickness, machined so that they can be arranged in a pyramid fashion to ensure rigidity, and having diameters ranging from 152 to 762 mm [6 to 30 in.]. The diameters of adjacent plates in the pyramid arrangement shall not differ by more than 152 mm [6 in.].

NOTE 1—A minimum of four different plate sizes is recommended for pavement design or evaluation purposes. For evaluation purposes alone, a single plate may be used, provided that its area is equal to the tire-contact area corresponding to what may be considered as the most critical combination of conditions of wheel load and tire pressure. For the purpose of providing data indicative of bearing index (for example, the determination of relative subgrade support throughout a period of a year), a single plate of any selected size may be used.

6.2.4 *Dial Gauges*, three or more, graduated in units of 0.02 mm [0.001 in.] and capable of recording a maximum deflection of 25.4 mm [1 in.], or other equivalent deflection-measuring devices.

6.2.5 *Deflection Beam*—A beam upon which the dial gauges shall be mounted. The beam shall be a 64-mm [2½-in.] standard black pipe or a 76 by 76 by 6-mm [3 by 3 by ¼-in.] steel angle or equivalent. It shall be at least 5.5 m [18 ft] long and shall rest on supports located at least 2.4 m [8 ft] from the circumference of the bearing plate or nearest wheel or supporting leg. The entire deflection measuring system shall be adequately shaded from direct rays of the sun.

6.2.6 *Miscellaneous Tools*, including a spirit level, for preparation of the surface to be tested and for operation of the equipment.

6.2.7 Fig. 1 shows a typical analog system configuration with dial gauges which requires manual data collection.



FIG. 1 Analog System Configuration

6.3 This subsection describes the digital system using a displacement transducer and load cell to capture the data during the test procedure. The description below is in compliance with DIN 18134.

6.3.1 *Plate Loading Apparatus*, consisting of a loading plate, an adjustable spirit level, and a loading system with hydraulic pump and jack assembly with high-pressure hose.

6.3.2 Devices for measuring the load applied and the settlement of the loading plate at right angles to the loaded surface, and means of calculating the strain modulus.

6.3.3 The reaction loading system shall produce a reaction load which is at least 10 kN greater than the maximum test load required. It may be a loaded truck or roller or any other object of sufficient mass.

6.3.4 Loading plates shall be made of Specification **A572/A572M** Gr. 50 (EN10025 grade S355J0) steel or equivalent material with the same stiffness and hardness. They shall be machined so as to have the flatness and roughness tolerances in accordance with **Figs. 2 and 3**. The loading plate shall have two handles (see **Fig. 2**).

6.3.5 Loading plates with a diameter of 300 mm shall have a minimum thickness of 25 mm.

6.3.6 Loading plates with a diameter of 600 mm or 762 mm shall have a minimum thickness of 20 mm and be provided with equally spaced stiffeners with even upper faces parallel to the plate bottom face to allow the 300-mm plate to be placed on top of it. Centering pins, and also clamps, if necessary, shall be provided to hold the upper plate in position (see **Fig. 3**).

6.3.7 Loading System:

6.3.7.1 The loading system consists of a hydraulic pump connected to a hydraulic jack via a high-pressure hose with a minimum length of 2 m. The system shall be capable of applying and releasing the load in stages.

6.3.7.2 For the pressure to be properly applied, the hydraulic jack shall be hinged on both sides and secured against tilting. The pressure piston shall act through at least 150 mm.

6.3.7.3 The height of the plate loading apparatus during operation should not exceed 600 mm. In order to compensate for differences in the heights of the vehicles used as reaction loads, elements shall be provided that allow the initial length of the hydraulic jack to be increased to at least 1.000 mm. Suitable means shall be provided to prevent buckling of these elements.

6.3.8 Force-Measuring Apparatus:

6.3.8.1 A mechanical or electrical force transducer shall be fitted between the loading plate and the hydraulic jack. It shall measure the load on the plate with a maximum permissible error of 1 % of the maximum test load.

6.3.8.2 The stress shall be indicated at a resolution of at least 0.001 MPa for a 300-mm loading plate and at least 0.0001 MPa for 600-mm and 762-mm loading plates.

6.3.8.3 The resolution of the force-measuring system shall be equivalent to that of the force transducer. The above requirements apply for temperatures from 0 °C to 40 °C.

6.3.9 Settlement-Measuring Device:

6.3.9.1 The arrangement in **Fig. 4** shows a settlement-measuring device with a rotatable contact arm (**Fig. 4(a)**) and one with a contact arm capable of being moved horizontally in axial direction (that is, with a slide bearing, see **Fig. 4(b)**) or direct measurement with gauge (**Fig. 4(1b)**) in the middle of the plate.

6.3.9.2 The measuring device with a rotatable contact arm is only suitable for tests in excavations up to 0.3 m deep. The measuring device with a contact arm capable of being moved horizontally in axial direction—or direct measuring—can also be used in deeper excavations.

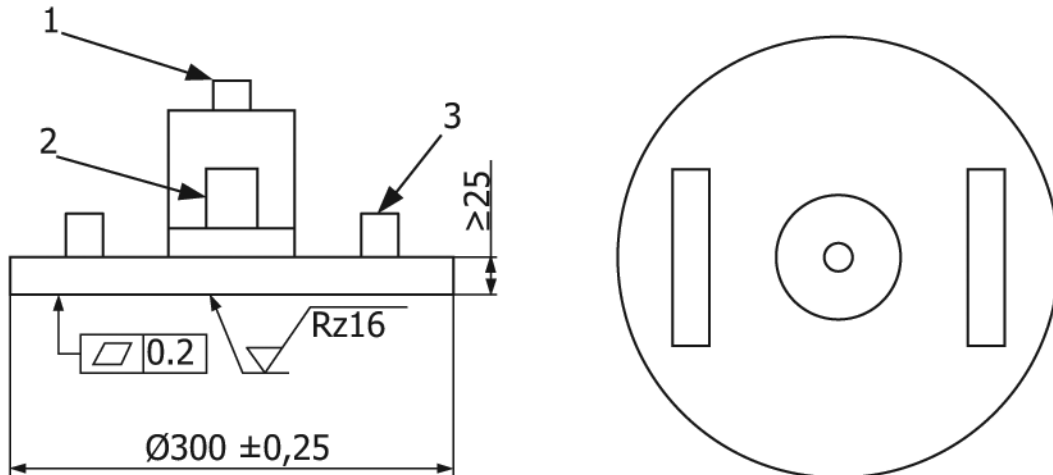

Dimensions in mm, General tolerances: ISO 2769-mL

Key

1 – Centering pin to hold the force transducer

2 – Measuring tunnel

3 – Handles

FIG. 2 300-mm Loading Plate with Measuring Tunnel

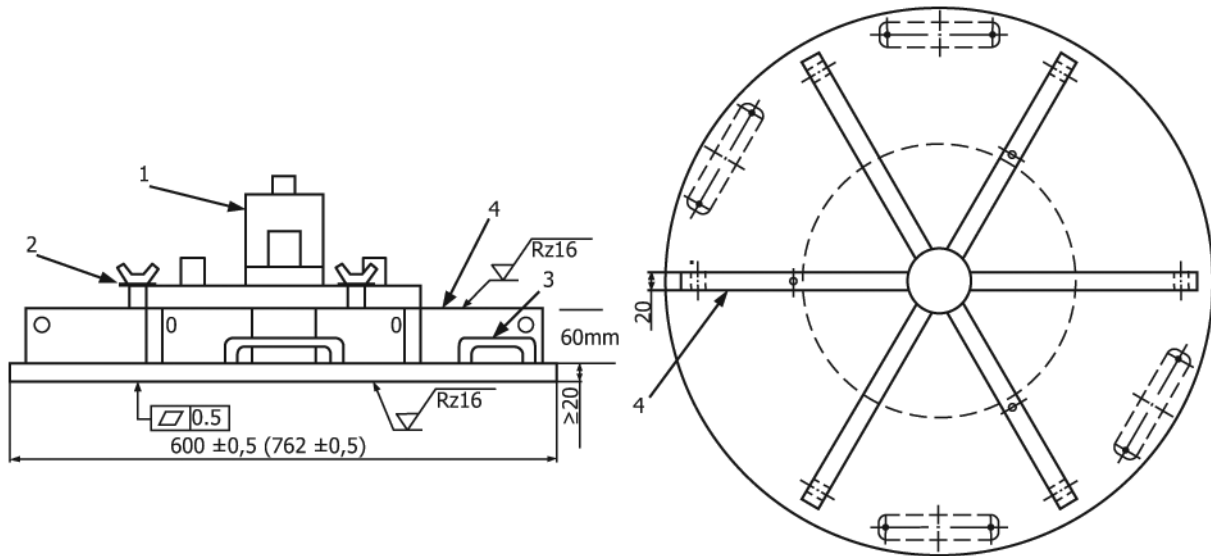

Dimensions in mm, General tolerances: ISO 2769-mL
 Key
 1 – 300 mm loading plate
 2 – Centering pins and clamps
 3 – Handles
 4 – Stiffeners

FIG. 3 Loading Plate 600 mm or 762 mm in Diameter with Equally Distributed Stiffeners

6.3.10 The settlement-measuring device consists of:

6.3.10.1 A frame supported at three points (see “2” in Fig. 4).

6.3.10.2 A vertically adjustable, torsion-proof, rigid contact arm (see “4” in Fig. 4), a displacement transducer, or dial gauge (see “1,” “1a,” or “1b” in Fig. 4).

6.3.10.3 The distance from the center of the loading plate to the centerline of the support shall be at least 1.5 m and shall not be greater than 1.6 m (see Fig. 4).

6.3.10.4 The $h_p:h_M$ ratio (see Fig. 4(a)) shall not exceed 2.0. The setting of the assembly shall be capable of being locked so that the $h_p:h_M$ ratio does not change during measurement.

6.3.10.5 The settlement-measuring device shall be capable of measuring the settlement of the loading plate with a maximum permissible error of 0.04 mm in the measuring range up to 10 mm when using a 300-mm or 600-mm loading plate, and in the measuring range up to 15 mm when using a 762-mm loading plate.

6.3.10.6 The indication shall have a resolution of at least 0.01 mm.

6.3.10.7 The above requirements apply for temperatures from 0 °C to 40 °C.

7. Hazards

7.1 The loading device should be secured to avoid movement during the test.

7.2 Operators should wear head protection when working under and around the loading device during the assembly/disassembly of the apparatus and performing the test.

7.3 The operator should avoid placing their hands between the loading device and the hydraulic jack assembly.

7.4 Use proper lifting techniques when moving base plates and transport cases to avoid back injury.

7.5 De-energize the hydraulic jack and piston prior to disassembling the testing apparatus.

8. Preparation of Apparatus

8.1 The following procedure shall be used to set up the apparatus for manually collecting data while performing the repetitive static plate load test to determine bearing strength.

8.1.1 Carefully center a bearing plate of the selected diameter under the jack assembly. Set the remaining plates of smaller diameter concentric with, and on top of, the bearing plate.

8.1.2 The loading plate shall lie on, and be in full contact with, the test surface. If necessary, make a thin bed (that is, only a few millimeters in thickness) of a mixture of sand and gypsum plaster, of gypsum plaster alone, or of fine sand, using the least quantity of materials required for uniform bearing. The plate shall be bedded on this surface by turning and slightly tapping on its upper face. When using gypsum plaster as bedding material, the plate shall be greased on its underside. Any excess gypsum plaster shall be removed with the spatula before it sets. Testing shall not begin until the gypsum plaster has set.

8.1.3 To prevent loss of moisture from the subgrade during the load test, cover the exposed subgrade to a distance of 1.8 m [6 ft] from the circumference of the bearing plate with a tarpaulin or waterproof paper.

8.1.4 Where unconfined load tests are to be made at a depth below the surface, remove the surrounding material to provide a clearance equal to one and one half bearing plate diameters

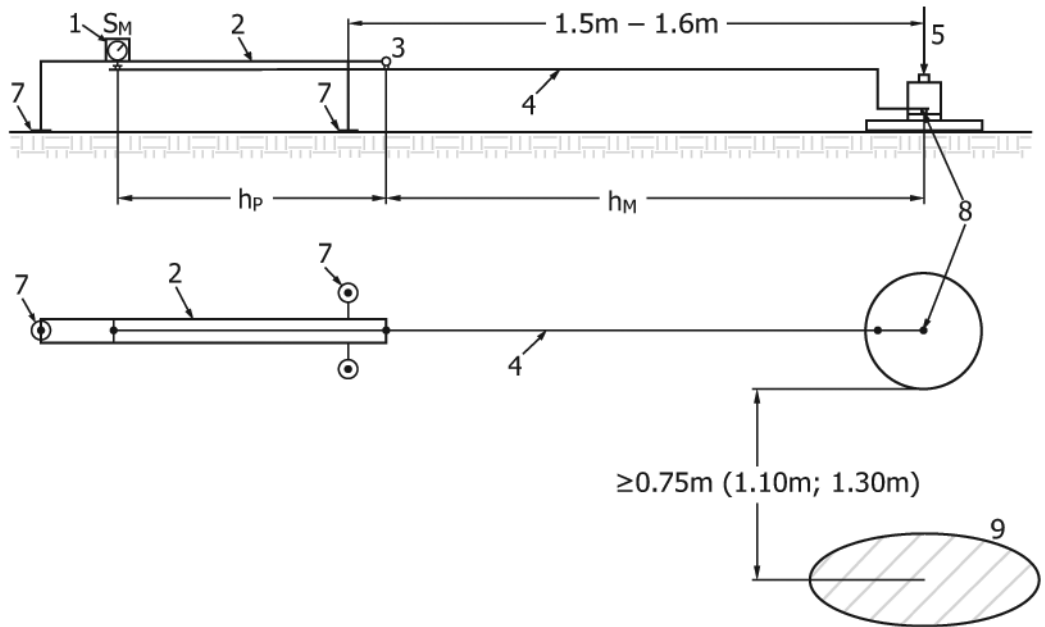

a) rotatable contact arm according to "weigh beam principle": measurement taking into account the lever ratio $h_p:h_M$

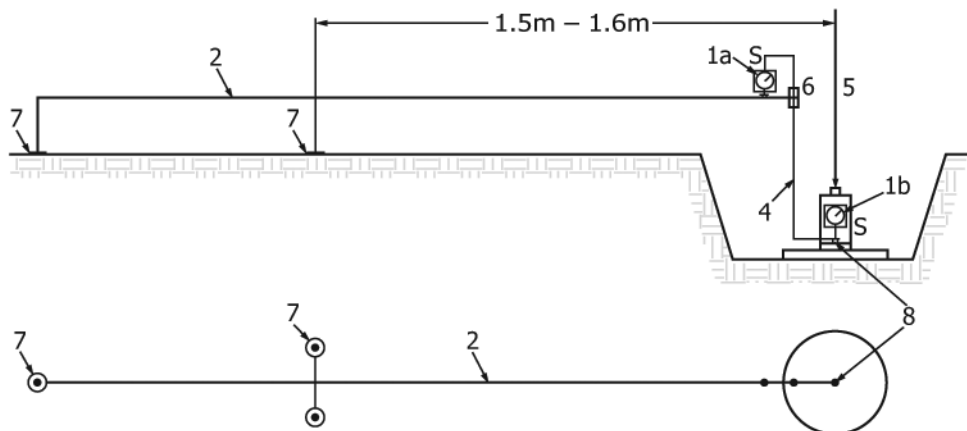

b) measurement of settlement in the lever ratio 1:1 with slide bearing (6) and gauge (1a) or direct measuring with gauge (1b) directly in the middle of the plate

Key

- | | |
|--|---|
| 1, 1a, 1b – Dial gauge or displacement transducer | 6 Slide bearing |
| 2 – Supporting frame | 7 Support |
| 3 – Fulcrum | 8 Stylus |
| 4 – Contact arm | 9 Area taken up by reaction load system |
| 5 – Load | |
| S_M, s – Settlement reading on dial gauge or displacement transducer | |

FIG. 4 Examples of Settlement-Measuring Devices (dimensions in meters)

from the edge of the bearing plate. For confined tests, the diameter of the excavated circular area shall be just sufficient to accommodate the selected bearing plate.

8.1.5 Use three dial gauges, so located and fixed in position as to indicate the average deflection of the bearing plate. The three gauges shall be set at an angle of 120° from each other,

equidistant from the circumference of the bearing plate, and near each extremity of a diameter of the bearing plate, 25.4 mm [1 in.] from the circumference.

8.2 The following procedure shall be used to set up the apparatus for automatically collecting data while performing the repetitive static plate load test with digital instrumentation to determine strain modulus, modulus of subgrade reaction, or bearing strength.

8.2.1 An area sufficiently large to receive the loading plate shall be levelled using suitable tools (for example, steel straightedge or trowel) or by turning or working the loading plate back and forth. Any loose material shall be removed.

8.2.2 The loading plate shall lie on, and be in full contact with, the test surface. If necessary, make a thin bed (that is, only a few millimeters in thickness) of a mixture of sand and gypsum plaster, of gypsum plaster alone, or of fine sand, using the least quantity of materials required for uniform bearing. The plate shall be bedded on this surface by turning and slightly tapping on its upper face. When using gypsum plaster as bedding material, the plate shall be greased on its underside. Any excess gypsum plaster shall be removed with the spatula before it sets. Testing shall not begin until the gypsum plaster has set.

8.2.3 To prevent loss of moisture from the subgrade during the load test, cover the exposed subgrade to a distance of 1.8 m [6 ft] from the circumference of the bearing plate with a tarpaulin or waterproof paper.

8.2.4 The hydraulic jack shall be placed onto the middle of, and at right angles to, the loading plate beneath the reaction loading system and secured against tilting. The minimum clearance between the loading plate and contact area of the reaction load shall be 0.75 m for a 300-mm plate, 1.10 m for a 600-mm plate, and 1.30 m for a 762-mm plate (see Fig. 4(a)).

8.2.5 The reaction load shall be secured against displacement at right angles to the direction of loading. Care shall be taken to ensure that the loading system remains stable throughout the test. These requirements also apply to inclined test surfaces.

8.2.6 Measurement of settlement shall be carried out using a displacement transducer.

8.2.7 In order to measure settlement, the stylus or displacement transducer (see Fig. 4) shall be placed in the center of the loading plate. The distance between the support for the supporting frame and the area taken up by the reaction load shall be at least 1.25 m. The transducer shall be set up so as to be vertical (see Fig. 4(a) and Fig. 4(b)).

8.2.8 When placing the loading plate, care shall be taken to ensure that the stylus of the contact arm can be passed without hindrance into the measuring tunnel in the plinth of the loading plate and positioned centrally on the plate.

8.2.9 The settlement-measuring device shall be protected from sunlight and wind. Care shall be taken to ensure that the device and the reaction loading system are not subjected to vibration during the test.

9. Calibration and Standardization

9.1 Load cells, displacement transducers, analog or digital gauges, and pressure gauges that make up the plate loading apparatus shall be calibrated before delivery or after repairs.

9.2 Calibration of the components should be performed once a year.

10. Conditioning

10.1 The plate load test may be carried out on coarse-grained and composite soils as well as on stiff to firm fine-grained soils. Care shall be taken to ensure that the loading plate is not placed directly on particles larger than one quarter of its diameter.

10.2 In the case of rapidly drying, granular sand, or soil which has formed a surface crust that has been disturbed in its upper zone, the disturbed layer shall be removed before the plate load test is carried out. The density of the soil under test shall remain as unchanged as possible.

10.3 For fine-grained soil (for example, silt, clay), the plate load test can only be carried out and evaluated satisfactorily if the soil is relatively stiff or firm in consistency. In case of doubt, the consistency of the soil under test can be checked with a small adjacent test pit at various depths up to a depth, d , below ground level (d = diameter of loading plate).

11. Procedure

11.1 The following procedure is presented for performing the repetitive static plate load test to determine bearing strength.

11.1.1 Each individual set of readings shall be averaged, and this value is recorded as the average settlement reading.

11.1.2 After the equipment has been properly arranged, with all of the dead load (jack, plates, and so forth) acting, seat the bearing plate and assembly by the quick application and release of a load sufficient to produce a deflection of not less than 0.25 mm [0.01 in.] nor more than 0.51 mm [0.02 in.], as indicated by the dials. When the dial needles come to rest following release of this load, reseal the plate by applying one half of the recorded load producing the 0.25 to 0.51-mm [0.01 to 0.02-in.] deflection. When the dial needles have then again come to rest, set each dial accurately at its zero mark.

11.1.3 Apply loads at a moderately rapid rate in uniform increments. The magnitude of each load increment shall be small enough to permit the recording of a sufficient number of load-deflection points to produce an accurate load-deflection curve (not less than six). After each increment of load has been applied, maintain the load until a rate of deflection of not more than 0.03 mm [0.001 in.]/min occurs for 3 min consecutively. Record load and deflection readings for each load increment. Continue this procedure until the selected total deflection has been obtained or until the load capacity of the apparatus has been reached, whichever occurs first. At this point, maintain the load until an increased deflection of not more than 0.03 mm [0.001 in.]/min for 3 min consecutively occurs. Record the

total deflection, after which release the load to load at which the dial gauges were set at zero, and maintain this zero-setting load until the rate of recovery does not exceed 0.03 mm [0.001 in.] for 3 min consecutively. Record the deflection at the zero-setting load.

11.1.4 From a thermometer suspended near the bearing plate, read and record the air temperature at half-hour intervals.

11.2 The procedure presented below shall be used when determining strain modulus or subgrade reaction in accordance with DIN 18134.

11.2.1 Preloading must be done prior to starting the test. The force transducer and displacement transducer shall be set to zero, after which a load shall be applied corresponding to a stress of 0.01 MPa when using a 300-mm or a 600-mm plate and to a stress of 0.005 MPa when using a 762-mm plate. The reading of the transducer shall not be reset to zero until at least 30 s after the preload has been applied.

11.2.2 To determine the strain modulus, E_v , the load shall be applied in not less than six stages, in approximately equal increments, until the required maximum stress is reached. Each change in load (from stage to stage) shall be completed within 1 min. The load shall be released in three stages, to 50 %, 25 %, and approximately 2 % of the maximum load.

11.2.3 Following unloading, a further (second) loading cycle shall be carried out in which, however, the load is to be increased only to the penultimate stage of the first cycle (so that the full load is not reached).

11.2.4 When increasing and decreasing the load, 120 s after the previous loading stage has been reached shall elapse before beginning the next stage. For road base testing, 60 s is sufficient. The load shall be held constant during this period. The reading shall be recorded at the termination of each loading stage (see [Tables 1 and 2](#)).

11.2.5 To determine the strain modulus for road construction purposes, a 300-mm loading plate shall be used and the load increased until a normal stress below the plate of 0.5 MPa is reached. If a settlement of 5 mm is reached first, the normal stress measured at this stage shall be taken as the maximum stress.

TABLE 1 300-mm Diameter Load Plate Summary (example)

Pressure (MPa)	Time to Hold Pressure (s)	
	Preload	
0.010		30
	First load cycle	
0.080		60
0.160		60
0.250		60
0.330		60
0.420		60
0.500		60
	Unload	
0.250		60
0.125		60
0.010		60
	Second load cycle	
0.080		60
0.160		60
0.250		60
0.330		60
0.420		60

TABLE 2 762-mm Diameter Load Plate Summary (example)

Pressure (MPa)	Time to Hold Pressure (s)	
	Preload	
0.001		30
	First load cycle	
0.010		60
0.020		60
0.040		60
0.080		60
0.120		60
0.160		60
0.200		60
	Unload	
0.100		60
0.050		60
0.001		60
	Second load cycle	
0.010		60
0.020		60
0.040		60
0.080		60
0.120		60
0.160		60

11.2.6 For a 600-mm loading plate, the limit values are 0.25 MPa (for normal stress) and 8 mm (for settlement), and for a 762-mm loading plate, 0.2 MPa and 13 mm.

11.2.7 If a test proceeds in an unexpected manner (for example, if the loading plate tips or sinks rapidly), the soil at the test site shall be dug up to a depth equal to the plate diameter. If any local inhomogeneity is encountered (for example, stones or soil of varying consistency), this shall be recorded.

11.2.8 For soils of low particle strength (for example, volcanic scoria), or where rapid deformation of the soil as the loading increases indicates imminent failure, the plate load test shall be terminated at lower normal stress values.

11.2.9 If, during the loading cycle, a higher load than intended is inadvertently applied, this load shall be maintained and a note made in the test report.

NOTE 2—In order to check the results obtained from the second loading cycle, once unloading in stages has been completed a third cycle may be carried out to the same maximum load. However, this shall be applied immediately after the second loading stage, without any further intermediate stages.

11.3 The following are summary tables for use with the 300-mm and the 762-mm diameter loading plates:

11.3.1 [Table 1](#) is a summary table for use of the 300-mm diameter loading plate.

11.3.2 [Table 2](#) is a summary table for use of the 762-mm diameter loading plate.

12. Calculation or Interpretation of Results

12.1 From the data obtained by the procedure, plot the total or unit load in Newtons [pounds-force] for each increment against the corresponding settlement in millimeters [inches]. Also plot the recovery after full release of load. Correction should be made for the zero-deflection point, taking into account the dead weight of the equipment and the seating load. From this graph, the relation of load and total deflection for that load, and the relation of rebound and residual deflection for the maximum load used, may be obtained.

12.2 Develop a load-settlement curve following the steps below:

12.2.1 For each load increment, the average normal stress, σ_0 , and the associated settlement reading, M , shall be recorded on the dial gauge or displacement transducer. For the assembly shown in Fig. 4(b), the settlement, s , shall be equal to the reading, M . For the assembly shown in Fig. 4(a), s is to be obtained by multiplying the settlement reading, M , by the lever ratio $h_p:h_M$, in accordance with Eq 1:

$$s = s_M \cdot \frac{h_p}{h_M} \quad (1)$$

12.2.2 The normal stresses shall be plotted against the settlement as shown in Fig. 5. A load-settlement fitting curve shall be drawn through the measuring points of the first loading cycle and repeat loading cycle. The measuring points from the

unloading cycle shall be joined in a straight line. The loading and unloading cycles shall be identified by directional arrows.

12.2.3 Calculation of the strain modulus, E_v , from the first and of the second loading cycle shall be based on load/settlement fitting curves. These shall be calculated by means of a second-degree polynomial according to Eq 2:

$$s = a_0 + a_1 \cdot \sigma_0 + a_2 \cdot \sigma_0^2 \quad (2)$$

where:

- σ_0 = average normal stress below the plate, MN/m²,
- s = settlement of the loading plate, mm,
- a_0 = constants of the second-degree polynomial, mm,
- a_1 = constants of the second-degree polynomial, mm/(MN/m²), and

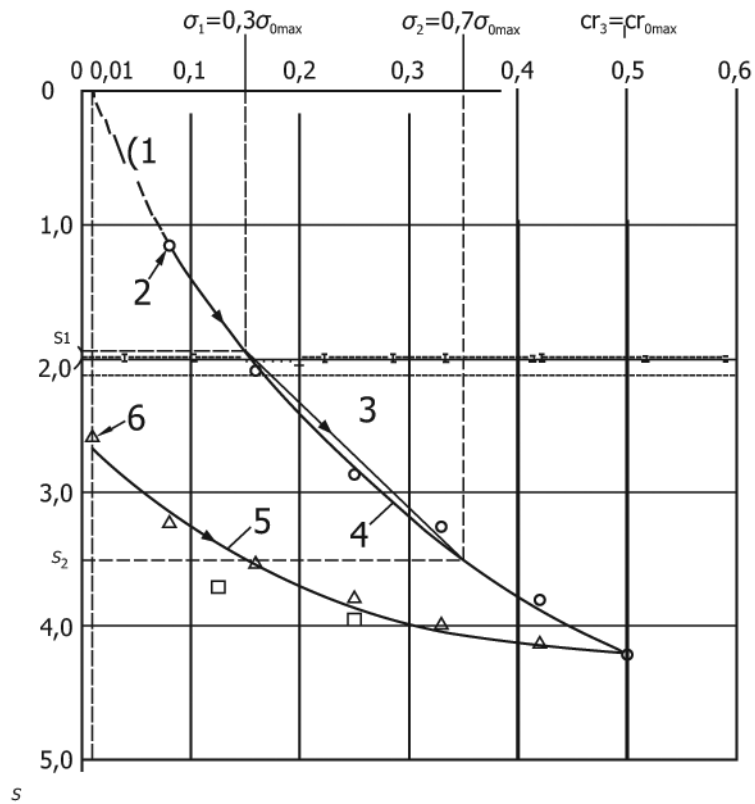

Key

- O Measurement points from the first loading cycle
- D Measurement points from the unloading cycle
- n Measurement points from the second loading cycle
- 1 Line connecting point (0,01 MN/m²; 0 mm) and the first point from the first loading cycle
- 2 First point from the first loading cycle
- 3 Secant between 0,3 · σ_{0max} and 0,7 · σ_{0max}
- 4 Quadratic parabola between the first and the last point from the first loading cycle
- 5 Quadratic parabola between the first and the last point from the second loading cycle
- 6 First point from the second loading cycle
- s Settlement in mm
- σ_0 Normal stress in MN/m²

FIG. 5 Load-Settlement Curve, Fitting Curves According to Tables 1 and 2 for the First and Second Loading Cycles

a_2 = constants of the second-degree polynomial, mm/(MN²/m⁴).

12.2.4 In order to determine the constants of the first loading cycle, the first stage of the first loading cycle in **Tables 1 and 2** shall be neglected.

12.2.5 In order to determine the constants of the second loading cycle, the first stage of the second loading cycle in **Tables 1 and 2** shall be taken into account.

12.2.6 In order to calculate the constants of the polynomial from the measuring values from the first and second loading cycles, normal equations **Eq X1.1-X1.3** in **Appendix X1** shall be evaluated. A computational aid programmed to deal with these equations shall be used.

12.2.7 If a computer program is used to determine the strain modulus, the program shall be checked using the calculations.

12.2.8 The strain modulus, E_v , in MPa, shall be calculated using **Eq 3**:

$$E_v = 1.5 \cdot r \cdot \frac{1}{a_1 + a_2 \cdot \sigma_{0\max}} \quad (3)$$

where:

E_v = strain modulus, MN/m²,
 r = radius of the loading plate, mm, and
 $\sigma_{0\max}$ = maximum average normal stress below the loading plate in the first loading cycle, MN/m².

12.2.9 The subscript “1” shall be used after E_v to denote the first loading cycle, and the subscript “2” to denote the second loading cycle. $\sigma_{0\max}$ from the first loading cycle shall also be used to determine the parameters of the second loading cycle.

13. Report

13.1 In addition to the continuous listing of all load, deflection, and temperature data, a record shall also be made of all associated conditions and observations pertaining to the test including the following:

- 13.1.1 Date.
- 13.1.2 Time of beginning and completion of test.
- 13.1.3 List of personnel.
- 13.1.4 Weather conditions.
- 13.1.5 Any irregularity in routine procedure.
- 13.1.6 Any unusual conditions observed at the test site.
- 13.1.7 Any unusual observations made during the test.
- 13.1.8 Location of test site.
- 13.1.9 Diameter of the loading plates.
- 13.1.10 Type of settlement-measuring device used, including lever ratio, if relevant.
- 13.1.11 Type of soil.
- 13.1.12 Type of bedding material below the plate.
- 13.1.13 Settlement readings and corresponding normal stresses; load-settlement curves.
- 13.1.14 Description of the soil conditions below the plate after testing.

14. Precision and Bias

14.1 The precision and bias of this test method for making repetitive static plate load tests on subgrade soils and flexible pavement components has not been determined. Soils and flexible pavement components at the same location may exhibit significantly different load-deflection relationships. No method presently exists to evaluate the precision of a group of repetitive plate load tests on soils and flexible pavement components because of the variability of these materials. The subcommittee is seeking pertinent data from users of this test method that may be used to develop meaningful statements of precision and bias.

15. Keywords

15.1 bearing plate; bearing capacity; deflection; pavements; plate load tests

ANNEX

(Mandatory Information)

A1. CALIBRATION OF PLATE LOADING APPARATUS

A1.1 General

A1.1.1 The plate loading apparatus is calibrated to verify its proper functioning and to ensure compliance of the loading and settlement-measuring devices with requirements.

A1.1.2 Calibration shall be carried out by a body that uses instruments with certified traceability.

A1.1.3 Calibration of the plate loading apparatus shall be repeated at regular intervals to ensure performance of the loading test in accordance with this standard.

A1.1.4 Prior to each calibration, the apparatus shall be checked for mechanical damage and proper functioning of all components. The results shall be stated in the calibration report.

A1.1.5 Calibrated loading and settlement-measuring devices shall be durably marked with labels giving the name and address of the calibration body and the validity of calibration.

A1.2 Check of Plate Loading Apparatus for Compliance with Requirements

A1.2.1 It shall be checked whether the plate loading apparatus fulfills the requirements regarding:

A1.2.1.1 Dimensions of loading plate (see 6.3.4 – 6.3.6).

A1.2.1.2 Indication (limit of error) and resolution of the force-measuring system (see 6.3.8).

A1.2.1.3 Indication (limit of error) and resolution of the settlement-measuring device (see 6.3.10.5 and 6.3.10.6).

A1.2.1.4 Distance between center of loading plate and centerline of support of contact arm assembly (see 6.3.10.3).

A1.2.1.5 Lever ratio of settlement-measuring device (see 6.3.10.4).

A1.3 Apparatus and Equipment Used for Calibration and Functional Testing

A1.3.1 *Force-Measuring System*—The following is required for calibration of the force-measuring system:

A1.3.1.1 Frame for mounting the force-measuring system of the plate loading apparatus.

A1.3.1.2 Class 2 reference compressive force transducer including a measurement amplifier.

A1.3.1.3 Apparatus as in 6.3.1, 6.3.7, and 6.3.8.

A1.3.2 *Settlement-Measuring Device*—The following is required for calibration of the settlement-measuring device:

A1.3.2.1 Micrometer or gauge blocks with nominal lengths from 1 mm to 15 mm.

A1.3.2.2 Surface suitable to receive calibration equipment.

A1.3.2.3 The complete settlement-measuring device as in 6.3.9.

A1.4 Calibration and Functional Test

A1.4.1 *Force-Measuring System*:

A1.4.1.1 The force-measuring system of the plate loading apparatus and reference compressive force transducer for calibration purposes shall be mounted centrally in the frame and subjected to a preload corresponding to a normal stress below the plate of 0.01 MPa or 0.001 MPa (first loading stage, Table A1.1). The load shall be applied using the loading system of the plate loading apparatus requiring calibration.

A1.4.1.2 For calibrating the force-measuring system and checking the correct functioning of the loading system, two loading cycles and one unloading cycle shall be carried out. The load increments shall be selected as a function of the plate diameter (see Table A1.1). Each increase/decrease in load from

stage to stage shall be completed within 1 min. The load shall be released in four stages (Nos. 6, 4, 2, and 1 according to Table A1.1). Whether loading or unloading, the interval between the end of one stage and the start of the next shall be 2 min, during which time the load shall be maintained. Each load shall be set on the force-measuring system, read on the reference compressive force transducer, and recorded in the calibration report.

A1.4.1.3 Calibration shall be carried out at an ambient temperature between 10 °C and 35 °C. The error of measurement in the indication, q , in %, is calculated as in Eq A1.1 in relation to F_{\max} :

$$q = \frac{F_i - F}{F_{\max}} \cdot 100 \quad (\text{A1.1})$$

where:

F_i = force indicated on the force-measuring system, kN,
 F = force indicated on the reference compressive force transducer, kN, and

F_{\max} = maximum load required for the plate loading test, kN (Loading Stage No. 8 according to Table A1.1).

A1.4.1.4 The limit of error of the force-measuring system (that is, 1 % of the maximum load in the plate load test in accordance with 6.3.8.1) shall not be exceeded.

A1.4.1.5 If the difference between the reading on the force-measuring system, F_i , and the reading on the reference gauge, F , exceeds F_{\max} by more than 1 % for the loading cycles and by more than 2 % for the unloading cycle in the plate loading test, the force-measuring system of the plate loading apparatus shall be adjusted in accordance with the manufacturer's instructions and the calibration repeated.

A1.4.1.6 The zero error shall not exceed 0.2 % of F_{\max} 1 min after the load has been completely removed.

A1.4.2 *Settlement-Measuring Device*:

A1.4.2.1 The contact arm assembly of the plate loading device shall be placed on a firm, even, horizontal surface and the dial gauge or displacement transducer mounted into the contact arm.

A1.4.2.2 For calibration, three different zero settings of the settlement-measuring device shall be carried out, and one series of measurements shall be taken for each zero setting. Each series shall comprise at least five measurements (beginning at the maximum calibration range). They shall be taken at

TABLE A1.1 Loading Stages as a Function of the Loading Plate Diameter

Loading Stage Number	Diameters of Loading Plates					
	300 mm		600 mm		762 mm	
	Load, F kN	Normal Stress, a_0 MPa	Load, F kN	Normal Stress, a_0 MPa	Load, F kN	Normal Stress, a_0 MPa
1	0.71	0.010	0.28	0.001	0.46	0.001
2	5.65	0.080	5.65	0.020	4.56	0.010
3	11.31	0.160	11.31	0.040	9.12	0.020
4	16.96	0.240	22.62	0.080	18.24	0.040
5	22.62	0.320	33.93	0.120	36.48	0.080
6	28.27	0.400	45.24	0.160	54.72	0.120
7	31.81	0.450	56.55	0.200	72.96	0.160
8	35.34	0.500	70.69	0.250	91.21	0.200

approximately equal intervals along the measuring range of the settlement-measuring device and cover the ranges up to 10 mm and up to 15 mm.

A1.4.2.3 The travelling distance for the calibration of the sensing device shall be 0.5 mm.

A1.4.2.4 The readings of the settlement-measuring device for each of the three-measurement series shall be recorded in the calibration report.

A1.4.2.5 Calibration shall be carried out at an ambient temperature between 10 °C and 35 °C. The ambient temperature at which the calibration is carried out shall be recorded.

A1.4.2.6 If one of the values indicated by the settlement-measuring device differs from the micrometer reading or the nominal value of the gauge block by more than 0.04 mm, the settlement-measuring device of the plate loading apparatus shall be adjusted in accordance with the manufacturer's instructions and the calibration repeated.

A1.4.2.7 When using plate loading apparatus with a settlement-measuring device based on the "weigh beam principle," the lever ratio $h_p:h_M$ shall be taken into account.

A1.5 Calibration Report Contents

A1.5.1 The calibration report shall include the following information:

A1.5.1.1 Applicant.

A1.5.1.2 Manufacturer of apparatus.

A1.5.1.3 Type of apparatus.

A1.5.1.4 Apparatus identification number.

A1.5.1.5 Year of manufacture.

A1.5.1.6 Ambient temperature during calibration.

A1.5.1.7 Date of calibration.

A1.5.1.8 Name of calibration body and person(s) responsible for calibration.

A1.5.1.9 Reference instruments used, with traceability certificates.

A1.5.1.10 General condition of plate loading apparatus on delivery.

A1.5.1.11 Deviations of loading plate and contact arm dimensions from specified dimensions.

A1.5.1.12 Information on the lever ratio of the settlement-measuring device.

A1.5.1.13 Deviations of the actual readings on the force-measuring device from the target values, in %.

A1.5.1.14 Deviations of the actual readings on the settlement-measuring device from the target values, in mm.

A1.5.1.15 Calibration results (test result).

APPENDIX

(Nonmandatory Information)

X1. PRINCIPLES UNDERLYING THE NORMAL EQUATIONS FOR CALCULATION OF THE CONSTANTS OF THE SECOND-DEGREE POLYNOMIAL FOR THE LOAD SETTLEMENT CURVE AND FOR CALCULATION OF THE STRAIN MODULUS, E_s

X1.1 The normal equations for calculation of the parameters for the following equation $s = a_0 + a_1 \cdot \sigma_0 + a_2 \cdot \sigma_0^2$ from the test results $(\sigma_{01}; s_1), (\sigma_{02}; s_2) \dots (\sigma_{0n}; s_n)$ are as follows:

$$a_0 \cdot n + a_1 \sum_{i=1}^n \sigma_{0i} + a_2 \sum_{i=1}^n \sigma_{0i}^2 = \sum_{i=1}^n s_i \quad (X1.1)$$

$$a_0 \sum_{i=1}^n \sigma_{0i} + a_1 \sum_{i=1}^n \sigma_{0i}^2 + a_2 \sum_{i=1}^n \sigma_{0i}^3 = \sum_{i=1}^n s_i \cdot \sigma_{0i} \quad (X1.2)$$

$$a_0 \sum_{i=1}^n \sigma_{0i}^2 + a_1 \sum_{i=1}^n \sigma_{0i}^3 + a_2 \sum_{i=1}^n \sigma_{0i}^4 = \sum_{i=1}^n s_i \cdot \sigma_{0i}^2 \quad (X1.3)$$

X1.1.1 Hence parameters a_0 , a_1 , and a_2 are known.

X1.2 The strain modulus E_{v1} can be calculated as a secant modulus according to elastic isotropic half-space theory. The secant is determined by the following points on the quadratic parabola (see Fig. 5): $P_1 (0.3 \sigma_{0max}; s_1)$; $P_2 (0.7 \sigma_{0max}; s_2)$.

X1.2.1 The strain modulus E_{v1} can thus be calculated as follows:

$$\begin{aligned} E_{v1} &= 1.5 \cdot r \cdot \frac{\Delta \sigma}{\Delta s} = 1.5 \cdot r \cdot \frac{\sigma_2 - \sigma_1}{s_2 - s_1} = 1.5 \cdot r \cdot \\ &\frac{0.7 \cdot \sigma_{0max} - 0.3 \cdot \sigma_{0max}}{[a_0 + a_1 \cdot 0.7 \cdot \sigma_{0max} + a_2 \cdot (0.7 \cdot \sigma_{0max})^2] - [a_0 + a_1 \cdot 0.3 \cdot \sigma_{0max} + a_2 \cdot (0.3 \cdot \sigma_{0max})^2]} \\ &= 1.5 \cdot r \cdot \frac{0.4 \cdot \sigma_{0max}}{0.4 \cdot a_1 \cdot \sigma_{0max} + (0.7^2 \cdot a_2 - 0.3^2 \cdot a_2) \sigma_{0max}^2} \\ &= 1.5 \cdot r \cdot \frac{1}{a_1 + a_2 \cdot \sigma_{0max}} \end{aligned}$$

X1.2.2 The strain modulus E_{v2} can also be calculated from the curve of the second loading cycle using σ_{0max} from the first loading cycle.



D1195/D1195M – 21

ASTM International takes no position respecting the validity of any patent rights asserted in connection with any item mentioned in this standard. Users of this standard are expressly advised that determination of the validity of any such patent rights, and the risk of infringement of such rights, are entirely their own responsibility.

This standard is subject to revision at any time by the responsible technical committee and must be reviewed every five years and if not revised, either reapproved or withdrawn. Your comments are invited either for revision of this standard or for additional standards and should be addressed to ASTM International Headquarters. Your comments will receive careful consideration at a meeting of the responsible technical committee, which you may attend. If you feel that your comments have not received a fair hearing you should make your views known to the ASTM Committee on Standards, at the address shown below.

This standard is copyrighted by ASTM International, 100 Barr Harbor Drive, PO Box C700, West Conshohocken, PA 19428-2959, United States. Individual reprints (single or multiple copies) of this standard may be obtained by contacting ASTM at the above address or at 610-832-9585 (phone), 610-832-9555 (fax), or service@astm.org (e-mail); or through the ASTM website (www.astm.org). Permission rights to photocopy the standard may also be secured from the Copyright Clearance Center, 222 Rosewood Drive, Danvers, MA 01923, Tel: (978) 646-2600; <http://www.copyright.com/>